

GETTING STARTED GUIDE

PXle-8861

This document includes instructions for installing and configuring your PXIe-8861 PXI Express controller module.

Contents

Getting Started.....	1
Unpacking.....	2
Installing the PXIe-8861 into a PXI Express Chassis.....	2
Data Storage.....	4
PXIe-8861 Front Panel.....	4
Removing the PXIe-8861 from a PXI Express Chassis.....	6
Common Configuration Questions.....	6
General Questions.....	7
Boot Options.....	7
Cables and Connections.....	8
Software Driver Installation.....	8
Upgrade Information.....	9
Troubleshooting.....	10
What if the controller does not boot?.....	10
What if I can't see the video?.....	11
My system boots fine as long as a particular module is not in my chassis. How do I boot the chassis with the module installed?.....	11
What if some modules installed in a remote Thunderbolt chassis show up in Windows Device Manager with yellow exclamation points?.....	11
What if some devices, when installed in a system with many remote chassis, show up in Windows Device Manager with yellow exclamation points?.....	11
My chassis or controller does not appear in MAX. How do I use MAX to identify and configure my PXI system?.....	11
My CMOS is corrupted. How do I set it back to default?.....	12
Worldwide Support and Services.....	13

Getting Started

This section includes instructions for unpacking and installing your PXIe-8861 controller. It also describes the controller's front panel connectors.



Caution Using the PXIe-8861 controller in a manner not described in this guide can impair the protection the controller provides.

Unpacking

The PXIe-8861 ships in an antistatic package to prevent electrostatic discharge from damaging device components. To prevent such damage when handling the device, ground yourself using a grounding strap or by holding a grounded object, such as your computer chassis, and complete the following steps:

1. Touch the antistatic package to a metal part of the chassis before removing the device from the package.



Caution Never touch the exposed pins of connectors.

2. Remove the device from the package and inspect the device for loose components or any other sign of damage.
3. Notify National Instruments if the device appears damaged in any way. Do *not* install a damaged device into your chassis.

Installing the PXIe-8861 into a PXI Express Chassis

To install the PXIe-8861 into a PXI Express chassis, complete the following steps.

1. Plug in your chassis before installing the PXIe-8861. The power cord grounds the chassis and protects it from electrical damage while you install the module.



Caution In some National Instruments chassis, you must ensure that the power LED is off. For more information about chassis power behavior, refer to the user manual for the specific chassis.



Caution To protect both yourself and the chassis from electrical hazards, leave the chassis off until you finish installing the PXIe-8861.

2. Remove any panels blocking access to the system controller slot (Slot 1) in the chassis.
3. Touch the metal part of the chassis case to discharge any static electricity that might be on your clothes or body.
4. Remove the protective plastic covers from the four bracket-retaining screws as shown in the following figure.

Figure 1. Removing Protective Plastic Covers

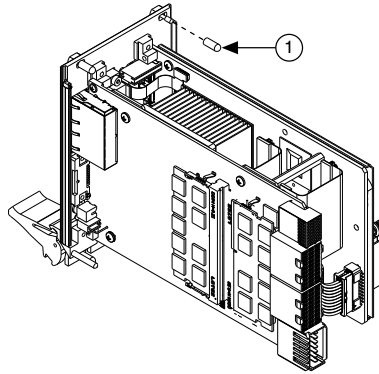

1. Protective Screw Cap (4x)

5. Make sure the injector/ejector handle is in its downward position. Align the PXIe-8861 with the card guides on the top and bottom of the system controller slot.



Caution Do *not* raise the injector/ejector handle as you insert the PXIe-8861. The module will not insert properly unless the handle is in its downward position so that it does not interfere with the injector rail on the chassis.

6. Hold the handle as you slowly slide the module into the chassis until the handle catches on the injector/ejector rail.
7. Raise the injector/ejector handle until the module firmly seats into the backplane receptacle connectors. The front panel of the PXIe-8861 should be even with the front panel of the chassis.
8. Tighten the four bracket-retaining screws on the top and bottom of the front panel to secure the PXIe-8861 to the chassis.
9. Check the installation.
10. Connect the keyboard and mouse to the appropriate connectors.
11. Connect the DisplayPort monitor video cable or adapter to the DisplayPort connector.
12. Connect devices to ports as required by your system configuration.
13. Power on the display.
14. Power on the chassis.
15. Verify that the controller boots. If it does not boot, refer to the *Troubleshooting* section.

The following figure shows a PXIe-8861 controller installed in the system controller slot of an NI PXIe-1082 chassis.

Figure 2. PXIe-8861 Installed in a PXI Express Chassis

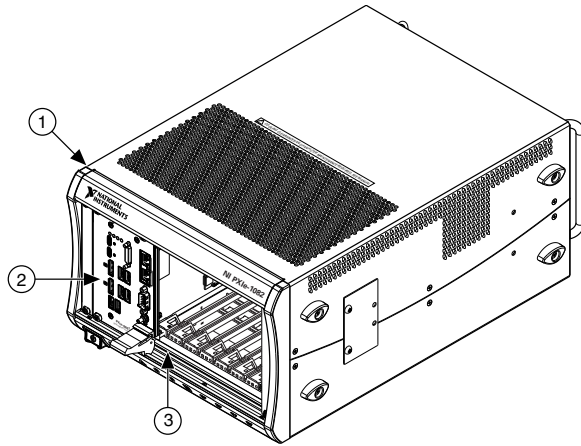

1. PXI Express Chassis
2. PXI Express Controller
3. Injector/Ejector Rail

Data Storage

The PXIe-8861 has the following data storage features:

- m.2 NVME internal solid state drive (500 GB or larger)
- USB storage support—USB CD/DVD-ROM, mass storage device, or floppy drive

PXIe-8861 Front Panel

The following figure shows the PXIe-8861 front panel layout.

Figure 3. PXIe-8861 Front Panel Layout

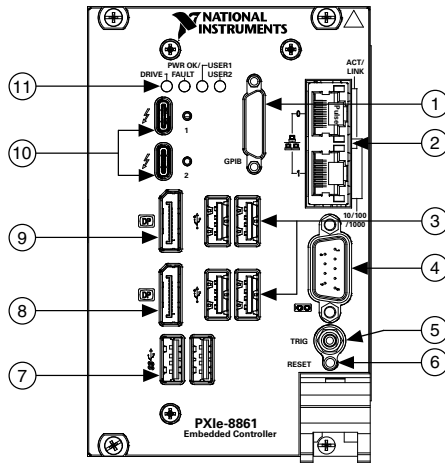

- | | |
|------------------|--------------------|
| 1. GPIB | 7. USB 3.0 |
| 2. Ethernet | 8. DisplayPort 1.1 |
| 3. USB 2.0 | 9. DisplayPort 1.2 |
| 4. RS-232 Serial | 10. Thunderbolt |
| 5. Trigger | 11. LEDs |
| 6. Reset Button | |

Front Panel Connectors

The following table lists various peripherals and their corresponding PXIe-8861 external connectors, bus interfaces, and functions.

Peripheral	External Connector	Description
Video (DisplayPort 1.1 and 1.2)	DisplayPort	ATI Radeon E6465 Embedded GPU
Thunderbolt 3	USB Type C (2 ports)	Thunderbolt 3 compliant, supports USB, PCI Express, and DisplayPort
Serial	COM1 (9-pin DSUB)	16550 RS-232 serial port
Ethernet Port 0	LAN (RJ45)	10/100/1000 Ethernet connection Intel I219 Wake on LAN
Ethernet Port 1	LAN (RJ45)	10/100/1000 Ethernet connection Intel I210

Peripheral	External Connector	Description
USB 2.0	USB 4-pin Series A stacked receptacle (4 ports)	Hi-Speed USB 2.0
USB 3.0	USB 9-pin Series A stacked receptacle (2 ports)	SuperSpeed USB, backwards compatible with USB 2.0
PXI trigger	Trigger (SMB)	Routing PXI triggers to or from the backplane trigger bus
GPIO	GPIO (25-pin Micro D)	General-Purpose Interface Bus, IEEE 488.2

Front Panel Features

The PXIe-8861 has two front panel LEDs that show PC status:

- **DRIVE LED**—Indicates when an access to the internal drive is occurring.
- **PWR OK/FAULT LED**—Indicates the controller status. The LED indicates one of the following states:
 - **Green ON steady**—PXI and onboard power is on and within regulation limits.
 - **Green BLINKING**—One of the onboard power supplies is operating outside the normal limits or the system power supply is out of regulation.
 - **OFF**—The controller is powered off.
 - **Red BLINKING**—The controller detected a power rail fault when trying to boot.
 - **Red SOLID**—The controller detected a thermal fault and has shut down to protect the system.
- **USER LEDs** — Two bi-color green/yellow LEDs (**USER1** and **USER2**) that you can define to meet the needs of your LabVIEW application.

Removing the PXIe-8861 from a PXI Express Chassis

To remove the PXIe-8861 from a PXI Express chassis, complete the following steps.

1. Power off the chassis.
2. Remove any cables that may be attached to the controller front panel.
3. Unscrew the four bracket-retaining screws in the front panel.
4. Press the injector/ejector handle down.
5. Slide the unit out of the chassis.

Common Configuration Questions

This section answers common configuration questions you may have when using a PXIe-8861 embedded controller.

General Questions

What do the LEDs on the front panel mean?

Refer to the LED status descriptions in the *Front Panel Features* section.

How do I check the configuration of the memory, storage drive, time/date, and so on?

You can view these parameters in the BIOS setup utility. Complete the following steps to enter the BIOS setup:

1. Reboot the PXIe-8861.
2. Press <Delete> during the system boot up.

Can I use the internal storage drive and an external storage drive at the same time?

Yes.

Boot Options

What devices can I boot from?

The PXIe-8861 can boot from the following devices:

- The internal drive.
- An external SCSI hard drive or SCSI CD/DVD-ROM if a SCSI adapter, such as the PXI-8214, is used.
- A network PXE server on the same subnet.
- An external USB mass storage device such as a USB hard drive, USB CD/DVD-ROM, or USB flash drive.
- Most PCI or PCI Express-based devices that provide an Option ROM.



Note There are limitations when booting from a USB device. You can install Windows 7 and later from a USB CD/DVD-ROM, but not earlier versions of Windows. The PXIe-8861 BIOS configures the USB devices so that they work in a DOS environment.

How do I configure the controller to boot from these devices?

You can configure the controller to permanently or temporarily change the boot order.

There are two methods.

- Enter Setup and select the **Boot** menu. You will see a list of all bootable devices, ordered by device type. You can set the boot order using <+> and <->. Set the order by device type and set the order for the devices listed within the device type.
- To boot from a different device without changing the boot order in the BIOS, press <F10> continuously while booting. After the BIOS completes the POST and just before

the controller boots the OS, the **Boot** menu is displayed. You can select the device type you want to boot from.

Cables and Connections

How do I plug both a PS/2 mouse and PS/2 keyboard into the controller?

The PXIe-8861 has no PS/2 connector, and you need to use a USB Y-splitter cable as shown below, or a similar device, to connect both a PS/2 mouse and PS/2 keyboard. National Instruments part number 778713-02 is such a cable and is available through the online catalog at ni.com/products.

Figure 4. Y-Splitter Cable

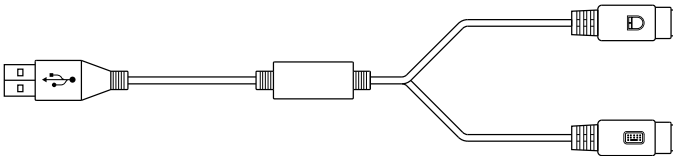

How do I connect a VGA monitor to the PXIe-8861?

You can use a DisplayPort-to-VGA adapter (part number 782271-01) available from National Instruments to connect a VGA monitor to a DisplayPort connector.

Software Driver Installation

How do I install or reinstall the video driver?

Refer to [What Peripheral Drivers Should I Use with My PXI or VXI Controller?](http://ni.com/support) at ni.com/support.

How do I install or reinstall the Ethernet driver?

Refer to [What Peripheral Drivers Should I Use with My PXI or VXI Controller?](http://ni.com/support) at ni.com/support.

How do I install software from a CD?

The compact size of the PXIe-8861 does not allow for an integrated USB CD/DVD-ROM drive. You have the following options:

- USB CD/DVD-ROM** You can install from a USB CD/DVD-ROM using a bootable installation CD.
- SCSI CD-ROM** Other types of CD-ROM drives are available. Check with the vendor to make sure Windows 10 supports the drive.

Mapped network drive You can use the Ethernet to connect to another computer. If you share the USB CD/DVD-ROM drive on the other computer, you can map the shared USB CD/DVD-ROM drive to a drive letter on the PXIe-8861.

A USB CD/DVD-ROM drive is available from National Instruments, part number 778492-01.

Upgrade Information

How do I upgrade system memory?

You can change the amount of installed RAM on the PXIe-8861 by augmenting or replacing the preinstalled SO-DIMM. Complete the following steps to replace the RAM.

1. Remove the PXIe-8861 from the PXI chassis.
2. Locate the SO-DIMM module on the side of the controller, as shown in the following figure.
3. Install the new SO-DIMM module into the slot.

PXIe-8861 System Memory Information

National Instruments offers the following types of SO-DIMMs for use with the PXIe-8861 controller.

- 8 GB, 2133 MHz DDR4 PC4-17000 compatible (NI part number 786777-01)
- 16 GB, DDR4-2133 MHz PC4-17000 compatible (NI part number 786776-01)



Note National Instruments has tested and verified that the DDR4 SO-DIMMs listed above work with the PXIe-8861 controller. We recommend you purchase your SO-DIMM modules from National Instruments. Other off-the-shelf modules are not guaranteed to work properly.

Figure 5. Installing a SO-DIMM in a PXIe-8861 Controller

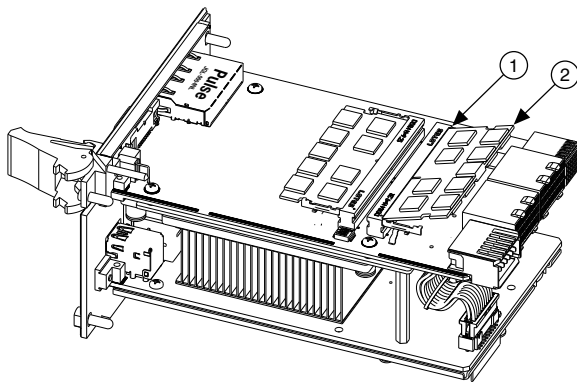

1. DDR4 SO-DIMM Socket
2. DDR4 SO-DIMM Module

How do I flash a new BIOS?

For more information, refer to [Determining and Upgrading PXI and VXI Embedded Controller BIOS Versions](#).

Where do I get the latest software drivers?

The latest National Instruments software is available from ni.com/downloads. For peripheral drivers, refer to [What Peripheral Drivers Should I Use with My PXI or VXI Controller?](#) at ni.com/support.

Troubleshooting

This section answers common troubleshooting questions you may have when using the PXIe-8861 embedded controller.

What if the controller does not boot?

Several problems can cause a controller not to boot. Here are some things to look for and possible solutions.

Things to Notice:

- Which LEDs come on? The **PWROK/FAULT** LED should stay lit green. The **Drive** LED should blink during boot as the disk is accessed.
- What appears on the display? Does it hang at some particular point (BIOS, Operating System, and so on)? If nothing appears on the screen, try a different monitor. Does your monitor work with a different PC? If it hangs, note the last screen output that you saw for reference when consulting National Instruments technical support.
- What has changed about the system? Did you recently move the system? Was there electrical storm activity? Did you recently add a new module, memory chip, or piece of software?
- Refer to your chassis documentation for additional troubleshooting steps.

Things to Try:

- Make sure the chassis is plugged in to a working power source.
- Check any fuses or circuit breakers in the chassis or other power supply (possibly a UPS).
- Make sure the controller module is firmly seated in the chassis.
- Remove all other modules from the chassis.
- Remove any nonessential cables or devices.
- Try the controller in a different chassis.
- Try a similar controller in the same chassis.
- Clear the CMOS.
- Recover the internal drive on the controller.
- Make sure the RAM is properly seated.

What if I can't see the video?

If you can see the BIOS screen at boot time but do not see video from the OS, the video card output may be set past the monitor limits. To resolve the problem, start Windows in Safe Mode by booting the controller from your recovery media and verifying that Windows troubleshooting options are available. If you do not see your BIOS screen on boot up, check all cables, adapters, and monitor connections and power.

My system boots fine as long as a particular module is not in my chassis. How do I boot the chassis with the module installed?

The most common cause of this problem is a damaged module. Try the module in a different chassis or with a different controller. Also, remove any external cables or terminal blocks connected to the system. If the module does not work in these cases, it is likely damaged. Contact the module manufacturer for further troubleshooting.

What if some modules installed in a remote Thunderbolt chassis show up in Windows Device Manager with yellow exclamation points?

Thunderbolt does not allow peripherals to take advantage of legacy IO Space. Some devices (such as serial or Ethernet modules) may rely on IO Space, creating resource allocation issues in the system. These modules should not prevent boot or operation of other devices, but will not function using IO Space.

For more information, go to ni.com/support.

What if some devices, when installed in a system with many remote chassis, show up in Windows Device Manager with yellow exclamation points?

PCI Express systems are allocated 256 unique bus segments. The Thunderbolt 3 ports on the PXIe-8861 consume 50 segments each (two ports total), leaving the residual segments for remote chassis connections. Disabling the Thunderbolt 3 ports from your PXIe-8861 BIOS allows those 100 bus segments to be allocated to remote chassis.

For more information, go to ni.com/support.

My chassis or controller does not appear in MAX. How do I use MAX to identify and configure my PXI system?

If you are using MAX to configure your PXI system, you must install the PXI Platform Services software on your controller to identify NI PXI and PXI Express chassis and modules

in MAX. You can install PXI Platform Services from the software CD included with your controller or from ni.com/downloads.

PXI Platform Services version 18.0 or later supports the PXIe-8861.

My CMOS is corrupted. How do I set it back to default?

There are two methods that you can use to reset the CMOS.

1. First Method
 - a) Enter the BIOS setup program.
 - b) Press <F9> to load BIOS defaults.
 - c) Answer **Y** (Yes) to the verification prompt.
 - d) Select **Save and Exit Setup**.
2. Second Method
 - a) Power off the chassis.
 - b) Remove the controller from the chassis.
 - c) Press the Clear CMOS button (SW1) for 2 to 3 seconds as shown in the following figure.
 - d) Reinstall the controller in the chassis.

Figure 6. Clearing the CMOS Contents

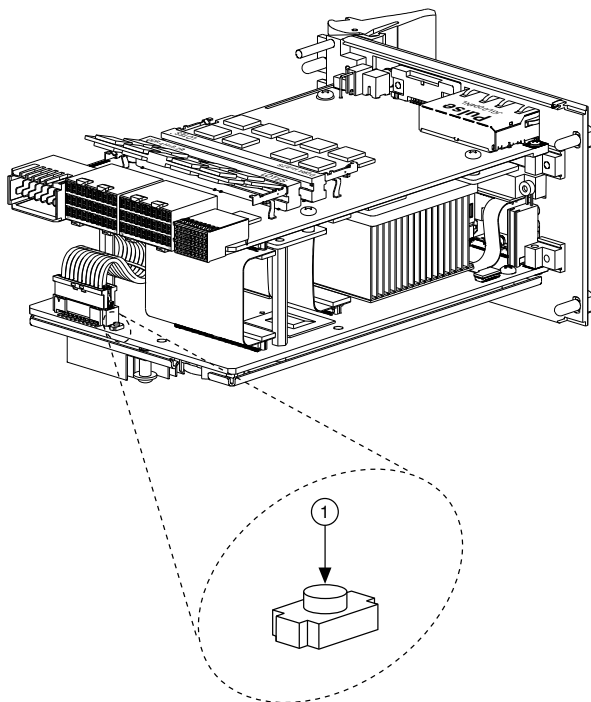

1. Push-Button Switch SW1

Worldwide Support and Services

The NI website is your complete resource for technical support. At ni.com/support, you have access to everything from troubleshooting and application development self-help resources to email and phone assistance from NI Application Engineers.

Visit ni.com/services for information about the services NI offers.

Visit ni.com/register to register your NI product. Product registration facilitates technical support and ensures that you receive important information updates from NI.

NI corporate headquarters is located at 11500 North Mopac Expressway, Austin, Texas, 78759-3504. NI also has offices located around the world. For support in the United States, create your service request at ni.com/support or dial 1 866 ASK MYNI (275 6964). For support outside the United States, visit the *Worldwide Offices* section of ni.com/niglobal to access the branch office websites, which provide up-to-date contact information.

Refer to the *NI Trademarks and Logo Guidelines* at ni.com/trademarks for information on NI trademarks. Other product and company names mentioned herein are trademarks or trade names of their respective companies. For patents covering NI products/technology, refer to the appropriate location: **Help»Patents** in your software, the `patents.txt` file on your media, or the *National Instruments Patent Notice* at ni.com/patents. You can find information about end-user license agreements (EULAs) and third-party legal notices in the readme file for your NI product. Refer to the *Export Compliance Information* at ni.com/legal/export-compliance for the NI global trade compliance policy and how to obtain relevant HTS codes, ECCNs, and other import/export data. NI MAKES NO EXPRESS OR IMPLIED WARRANTIES AS TO THE ACCURACY OF THE INFORMATION CONTAINED HEREIN AND SHALL NOT BE LIABLE FOR ANY ERRORS. U.S. Government Customers: The data contained in this manual was developed at private expense and is subject to the applicable limited rights and restricted data rights as set forth in FAR 52.227-14, DFAR 252.227-7014, and DFAR 252.227-7015.

© 2019 National Instruments. All rights reserved.

377624B-01 January 14, 2019